

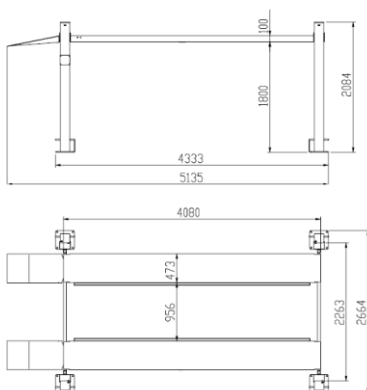

- The best choice for parking and simple repair
- Hydraulic cable driven lifting system
- Manual or electric single point release
- Automatic lock system ensure safety at different heights
- Maintenance free load bearing
- Stop blocks in all posts for added safety
- Moveable drip trays prevent pollution of vehicle on floor
- Caster kit for moving the lift easily
- 120% capacity dynamic load test and 150% capacity static load test
- Italian oil seal to make sure no oil leakage
- Solenoid valve with emergency manual drop function
- Optional manual pump for lock release in case of power off.
- Optional 24V control box and solenoid valve

Model No.	Lifting Capacity	Lifting Height	Width Between Posts	Width Between Runways	Outer Dimensions /L*W*H	Rise/Drop Time	Power
DFP608(E)	3700kgs/ 8000lbs	1800mm	2263mm	956mm	5135*2664*2084mm	65/60s	2.2kw
DFP608N(E)	3700kgs/ 8000lbs	1900mm	2263mm	956mm	5244*2664*2136mm	65/60s	2.2kw
DFP608XLT(E)	3700kgs/ 8000lbs	2000mm	2441mm	1134mm	5629*2842*2340mm	70/65s	2.2kw



DFP608/DFP608E

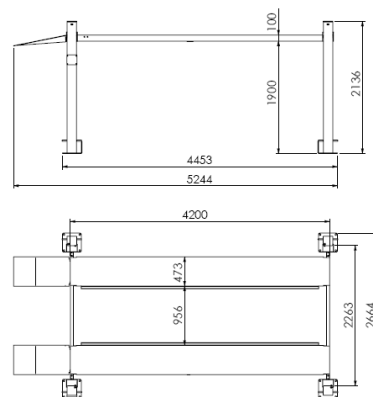

DFP608N/DFP608NE

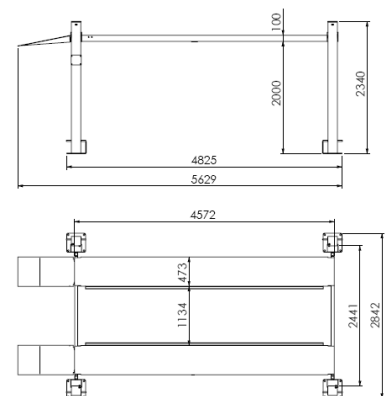

DFP608XLT/DFP608XLTE



- Can be used in household or office building parking lot.
- Posts can be shared, more economic and steady.
- Dual-cylinder lifting system, more stable and reliable
- Chain-equalization system
- Single manual or e-lock release system, safe and reliable
- Wear-resistant, heat-resistant and high strength macromolecular polyethylene slide blocks
- Optional wave plate or diamond plate, you can choose hot galvanizing, electroplating or powder spray
- Mold machining through the whole process so that the parts are universal and interchangeable
- Pass 120% capacity dynamic load test and 150% capacity static load test.
- Italian oil seal to make sure no oil leakage
- Solenoid valve has the emergency manual lock release function.
- Optional manual pump on power unit in case of power outage.
- Optional 24v control box solenoid valve and electromagnet.
- Optional infrared alarm device.

Model No.	Lifting Capacity	Lifting Height	Runway Width	Outer Dimensions(L*W*H)	Rise/Drop time	Power
DTPP606L	2700kgs/ 6000lbs	1600/1800 mm	2117mm	4208*2616*3109m m	90/75s	2.2kw
DTPP606H	2700kgs/ 6000lbs	1650/2100 mm	2117mm	4208*2616*3539m m	95/80s	2.2kw

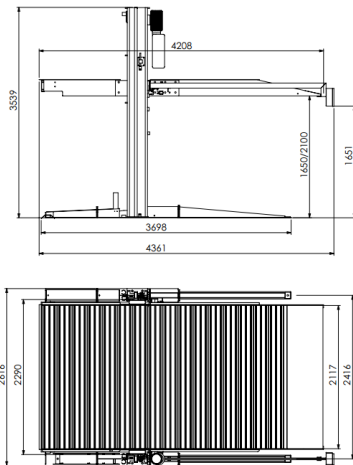

DTPP606L

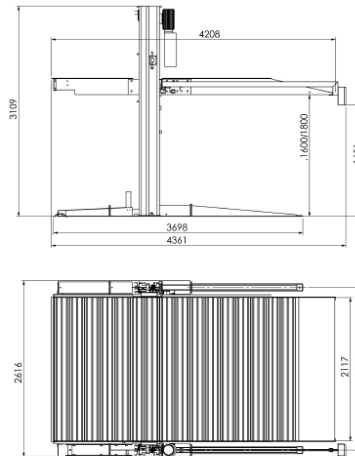

DTPP606H

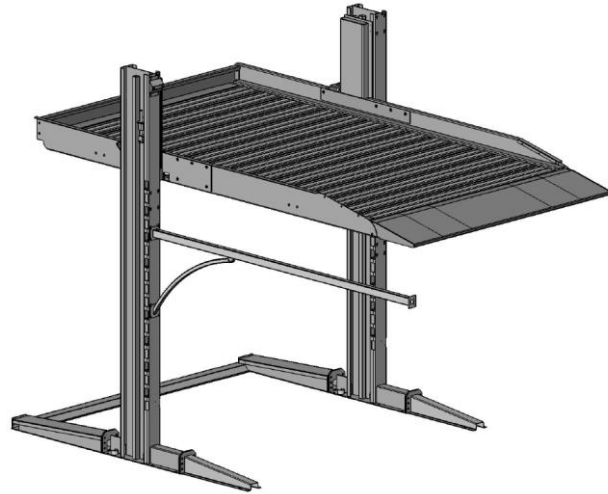

- Can be used in household or office building parking lot.
- Posts can be shared, more economic and steady.
- Dual-cylinder lifting system, more stable and reliable
- Chain-equalization system
- Single manual or e-lock release system, safe and reliable
- Wear-resistant, heat-resistant and high strength macromolecular polyethylene slide blocks
- Optional "wave" plate or "diamond" plate, hot galvanized, electroplated or powder sprayed.
- Pass 120% capacity dynamic load test and 150% capacity static load test.
- Italian oil seal to make sure no oil leakage
- Solenoid valve has the emergency manual lock release function.
- Optional manual pump on power unit in case of power outage.
- Optional 24v control box, solenoid valve and electromagnet
- Optional infrared alarm system.

Model No.	Lifting Capacity	Lifting Height	Runway Width	Outer Dimensions(L*W*H)	Rise/Drop time	Power
DTPP605	2700kgs/ 6000lbs	1600/1840mm	2117m	4256*2652*2796m	45/40s	2.2kw

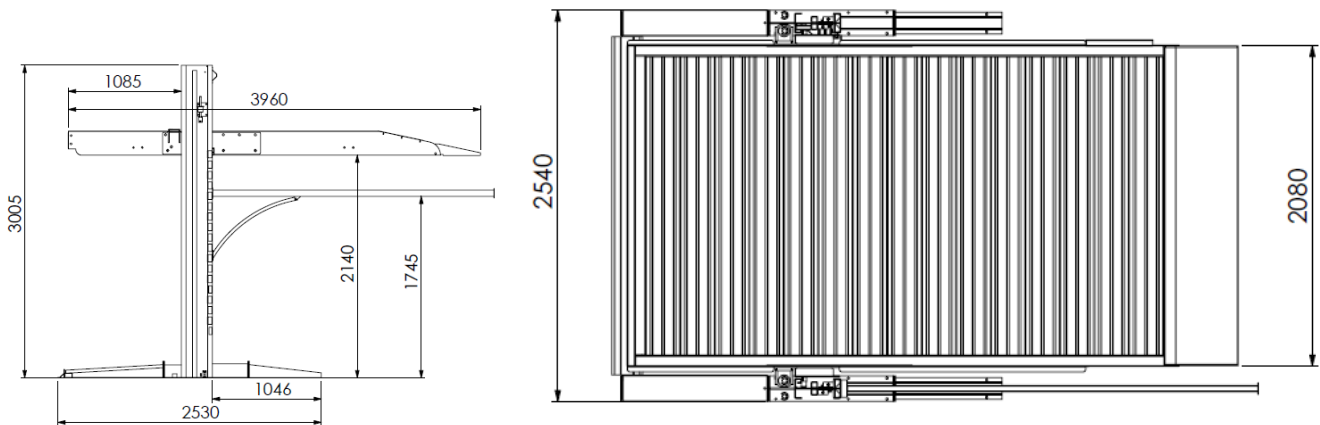



- Can be used in household or office building parking lot.
- Dual-cylinder lifting system, more stable and reliable
- Connecting shaft to ensure synchronous balancing
- Low post, faster lifting and lowering speed.
- Adjustable platform angle, suitable for low ceiling garage
- Single manual lock release system, safe and reliable.
- Pass 120% capacity dynamic load test and 150% capacity static load test.
- Italian oil seal to make sure no oil leakage
- Solenoid valve has the emergency manual lock release function.
- Optional manual pump on power unit in case of power outage.
- Optional 24v control box and solenoid valve
- Optional infrared alarm system.

Model No.	Lifting Capacity	Lifting Height	Runway Width	Outer Dimensions(L*W*H)	Rise/Drop time	Power
DEP606	2700kgs/6000lbs	1900mm	2002mm	3814*2580*1955mm	45/4s	2.2kw

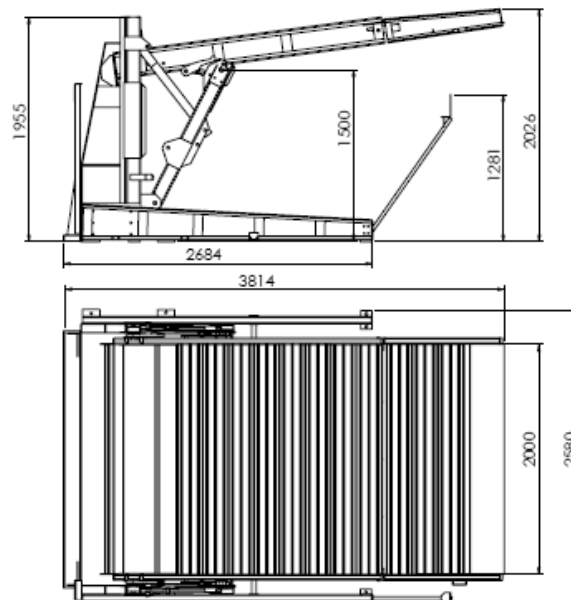



- Can be used in household or office building parking lot.
- Post can be shared, more economic and steady.
- Dual-cylinder lifting system, more stable and reliable
- The whole sliding framework synchronous balancing system.
- Single manual lock release system , safe and reliable.
- Optional “wave” plate or “diamond” plate, hot galvanized, electroplated or powder sprayed.
- Pass 120% capacity dynamic load test and 150% capacity static load test.
- Italian oil seal to make sure no oil leakage.
- Solenoid valve has the emergency manual lock release function.
- Optional manual pump on power unit in case of power outage.
- Optional 24v control box and solenoid valve.
- Optional infrared alarm device.

Model No.	Lifting Capacity	Lifting Height	Runway Width	Outer Dimensions(L*W*H)	Rise/Drop time	Power
DTPP706	2700kgs/6000lbs	2050mm	2060mm	4349*2713*2886mm	45/40s	2.2kw

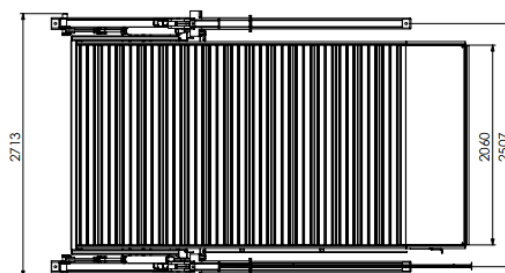
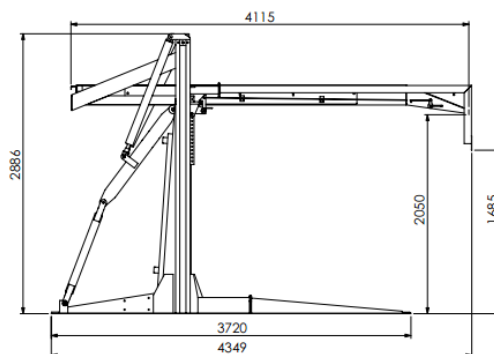



- Space-saving single post design, free entrance and exit for driver
- Single hydraulic cylinder , chain -driven system, faster lifting and lowering speed.
- Single electric or manual lock release system, safe and reliable
- Wear-resistant, heat-resistant and high strength Macromolecular polyethylene slide block
- Optional “wave” plate or “diamond” plate platforms, hot galvanized, electroplated or powder sprayed
- Automatic arm lock release
- Pass 120% capacity dynamic load test and 150% capacity static load test.
- Italian oil seal to make sure no oil leakage
- Solenoid valve has the emergency manual lock release function.
- Optional manual pump on power unit in case of power outage.
- Optional 24v control box, solenoid valve and electromagnet.

Model No.	Lifting Capacity	Lifting Height	Runway Width	Outer Dimensions(L*W*H)	Rise/Drop time	Power
DSPP607	3200kgs/ 7000lbs	2000mm	2000mm	4280*2852*3076 mm	50/45s	2.2kw

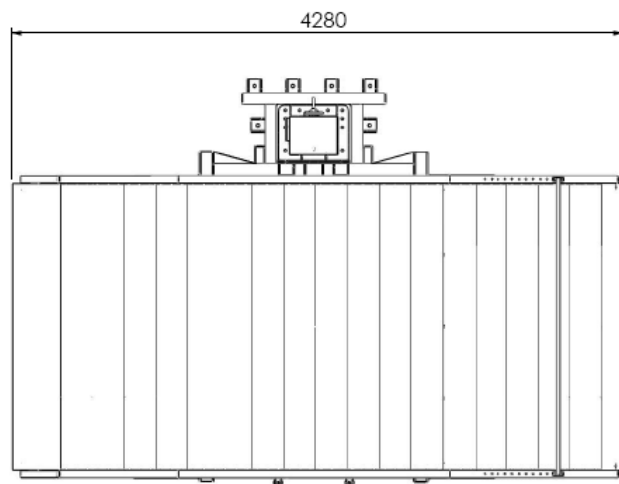
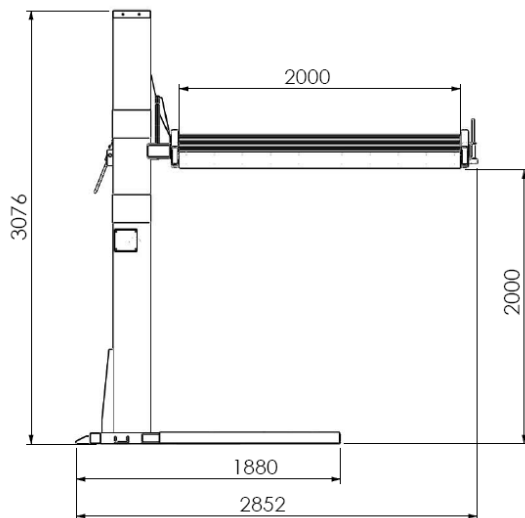



- Can be used in household or office building parking lot.
- Graceful and Compact configuration.
- Driven by hydraulic cylinders directly, equalizer ensures the synchronization and level of platform.
- Simple and practical lock system, automatic lock and release system, safe and reliable.
- Optional “wave” plate or “diamond” plate, hot galvanized, electroplated or powder sprayed.
- Pass 120% capacity dynamic load test and 150% capacity static load test.
- Italian oil seal to make sure no oil leakage
- Solenoid valve has the emergency manual lock release function.
- Optional manual pump on power unit in case of power off.
- Optional 24v control box and solenoid valve.
- Optional infrared alarm device

Model No.	Lifting Capacity	Lifting Height	Runway Width	Outer Dimensions(L*W*H)	Rise/Drop time	Power
DSPL606	2700kgs/6000lbs	2000mm	2126mm	4847*2562*2077mm	60/50s	2.2kw

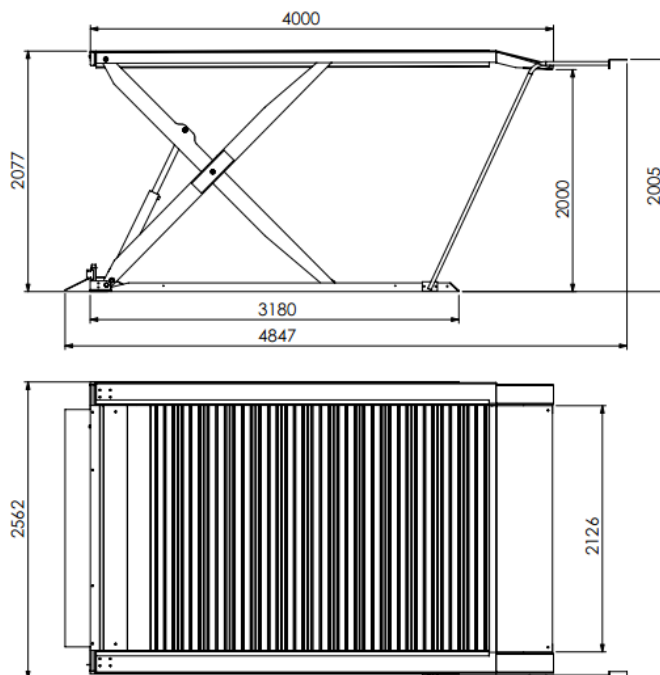

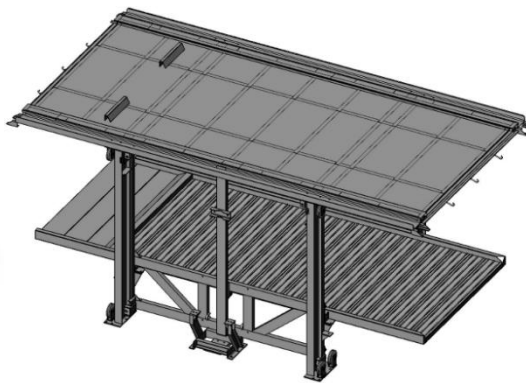

- Simple operation, economical and practical design, 1 parking space for 2 cars
- Pit type stacker, can be used in household or office building parking lot.
- Sharing post/feet structure which allows for space saving.
- No steel structure above ground, simple and graceful.
- The upper and lower space are fixed together, normally, the system lower to the pit, so the driver can park the car on upper platform directly, or rise the system to park the car on the lower platform.
- Multiple safety protection devices.
- Optional hydraulic oil cylinder or motor & chain driven mode.
- Optional "wave" plate or "diamond" plate platform, hot galvanized, electroplated or powder sprayed.
- Passed 120% capacity dynamic load test and 150% capacity static load test.
- Italian oil seal to make sure no oil leakage, inner anti-explosion valve in case of platform drop
- Optional infrared alarm device.

Model No.	Lifting Capacity	Lifting Height	Runway Width	Outer Dimensions (L*W*H)	Rise/Drop time	Power
DPS2-5A	5000kgs/11000lbs	1680mm	2000mm	5460*3172*2531mm	55/50s	2.2kw
DPS2-5B	5000kgs/11000lbs	1790mm	2095mm	5073*2378*4270mm	55/50s	2.2kw

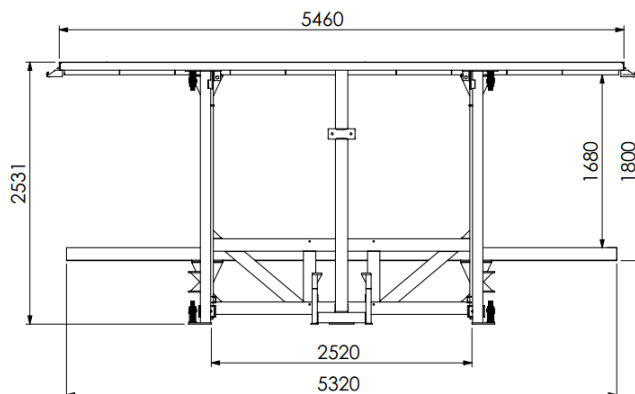
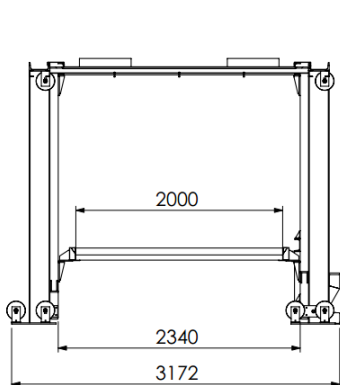

DPS2-5A

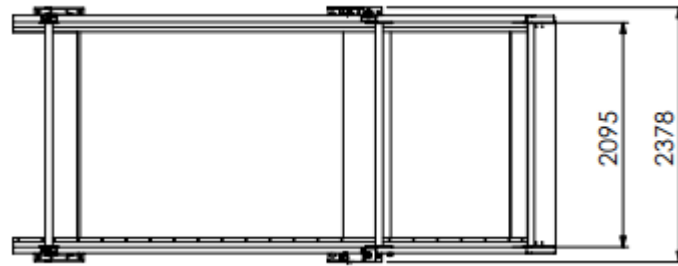
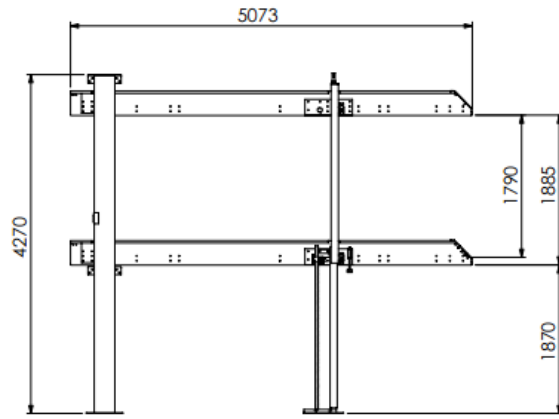

DPS2-5B



- Simplicity of operation, economic and practical design, 1 parking space for 3 cars
- Pit type stacker, can be used in household or office building parking lot.
- Post can be shared, more economic and steady.
- 3 parking spaces are fixed together and move concomitantly.
- Multiple safety protection devices.
- Optional hydraulic oil cylinder or motor & chain driven mode.
- Optional "wave" plate or "diamond" plate, you can choose hot galvanizing, electroplating or powder spray
- Pass 120% capacity dynamic load test and 150% capacity static load test.
- Italian oil seal to make sure no oil leakage
- Optional infrared alarm device.

Model No.	Lifting Capacity	Lifting Height	Runway Width	Outer Dimensions (L*W*H)	Rise/Drop time	Power
DPS3-7.5	7500kgs/16500lbs	1680mm	2000mm	5460*3172*4336mm	55/50s	4kw

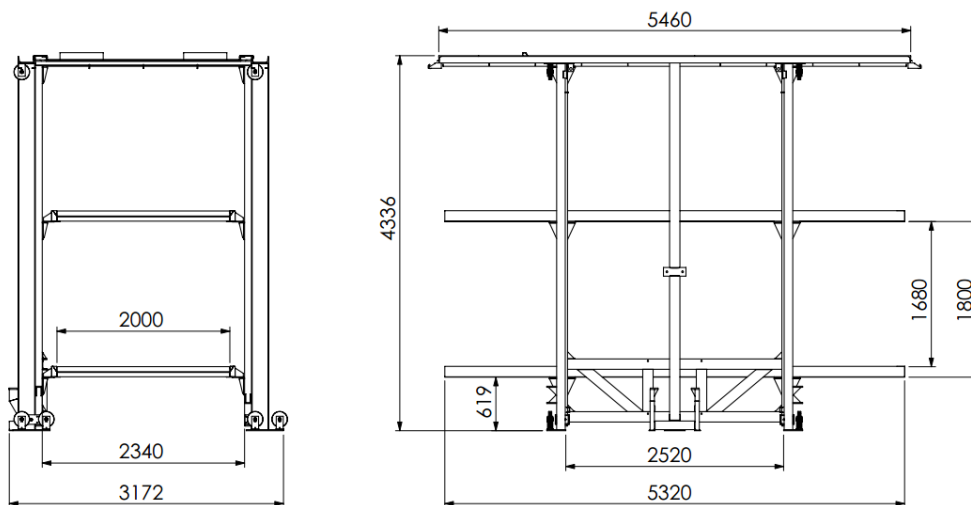

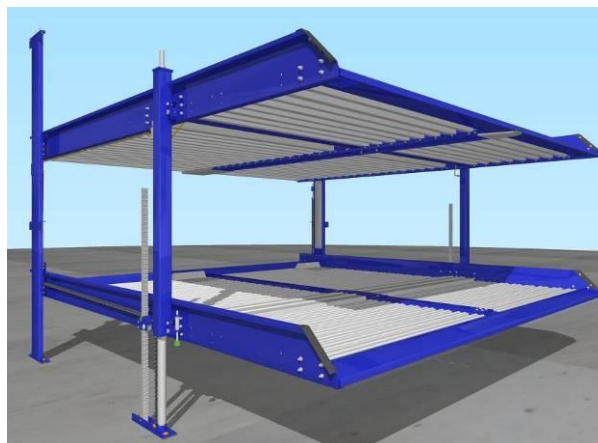

- Space saving garage system, economical and practical design, 4 cars on 2 platforms.
- Pit type stacker, it can be used in household or office building parking lot.
- The Right & Left sides are balanced by gear and spline synchronously to ensure steady transmission.
- Driven by hydraulic cylinders directly, car in upper layer can drive in or out directly, car in below layer can drive in or out after lift.
- Optional “wave” plate or “diamond” plate; hot galvanized, electroplated or powder sprayed options
- Pass 120% capacity dynamic load test and 150% capacity static load test.
- Italian oil seal to make sure no oil leakage, inner anti-explosion valve in case of platform drop
- Optional alarm device for unsecured garages.

Model No.	Lifting Capacity	Lifting Height	Runway Width	Outer Dimensions (L*W*H)	Rise/Drop Time	Power
DPS4-10	10000kgs/22000lbs	1784mm	2395mm	5078*5276*4270mm	55/50s	4kw

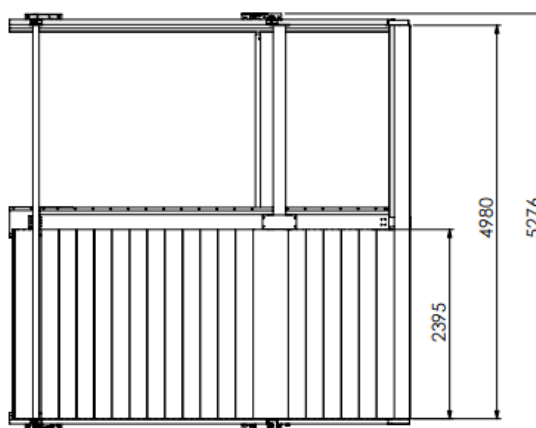
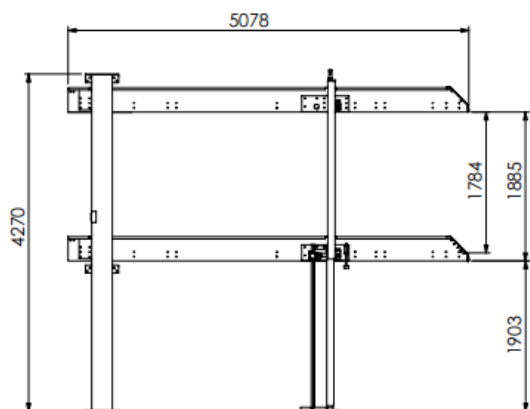

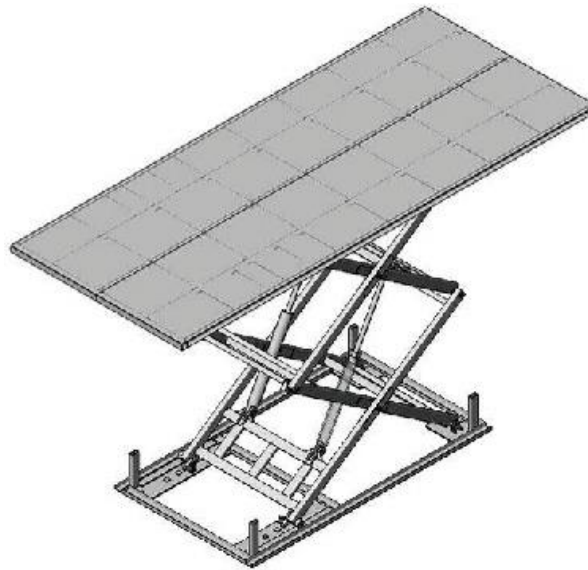

- Lifting height can reach 5m, it can lift car from first floor to second floor.
- Hydraulic oil cylinder transmission, more steady and reliable
- Electrical or pneumatic lock release system, can set locking mechanism at different heights as needed.
- One piece platform design, steady for car driving in or out.
- Pass 120% capacity dynamic load test and 150% capacity static load test.
- Italian oil seal to make sure no oil leakage, inner anti-explosion valve in case of platform drop.

Model No.	Lifting Capacity	Lifting Height	Runway Width	Outer Dimensions (L*W*H)	Rise/Drop Time	Power
DSP6000	2700kgs/6000lbs	0-2950mm	2500mm	6050*2500*3500mm	110/100s	3.7kw

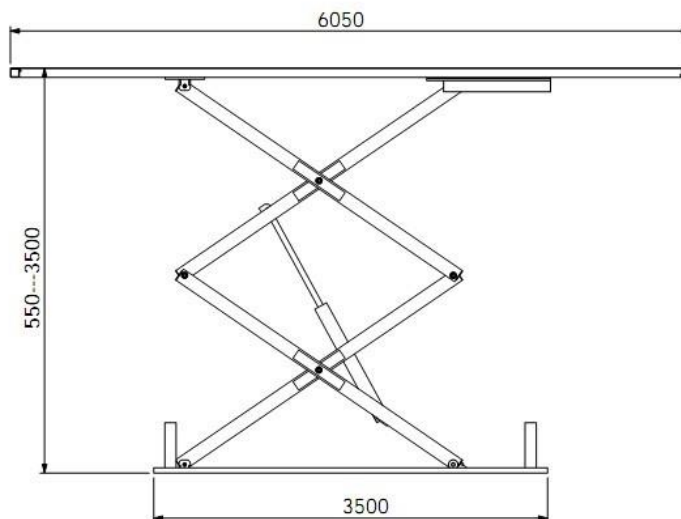
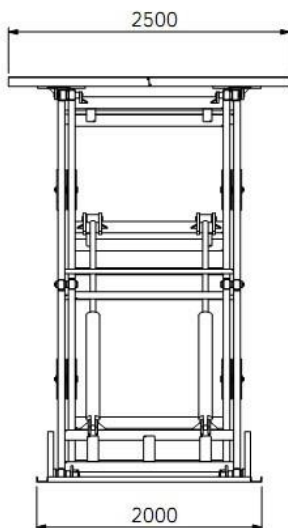

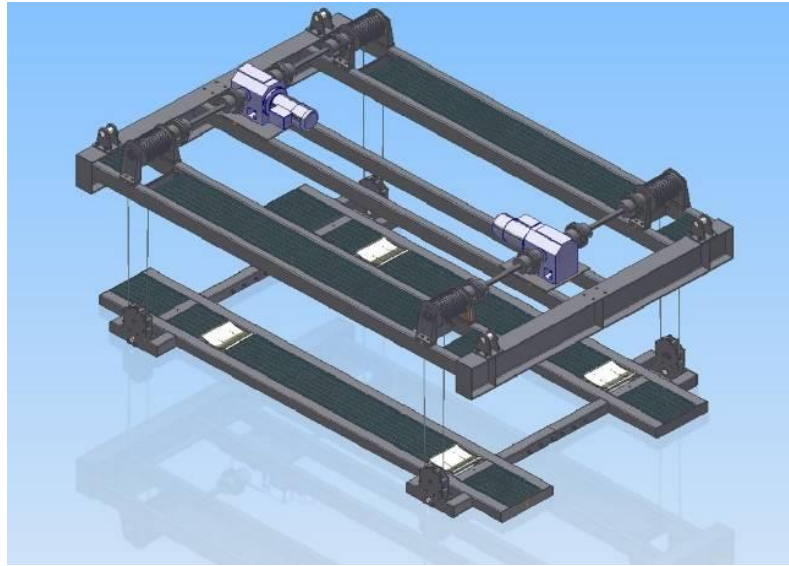
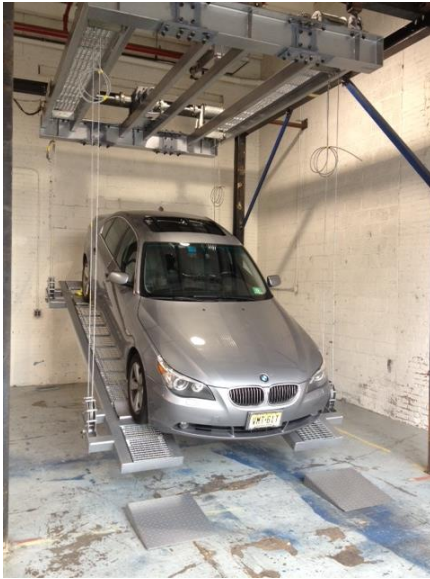

Description

1. This model is hung on the roof to save floor space.
2. The system is lifted by two deceleration motors with automatic braking device; it allows display of the cars and view from different angles.
3. Controlled by PLC, remote operation.
4. Platform is made of metal grid, the wheels positions for different wheelbase cars can be adjusted, optional spotlights installed.

Model No.	Lifting Capacity	Overall Length	Overall Width	Outer Dimensions (L*W)	Rise/Drop Time	Power
DHP806	2700kgs/6000lbs	4905mm	2794mm	4905*2794mm	30/30s	2.2kw

